

LAB GROWN DIAMOND

GCAL LG343050485

November 20, 2024



The fingerprint system for diamonds



ID No. NY02-725489

Gemprint is the unique optical fingerprint of your lab grown diamond. This patented technology is positive, forensic identification. Protect your investment and receive discounts up to 10% off your annual insurance premiums.

Register your diamond at Gemprint.com

Laser Inscription

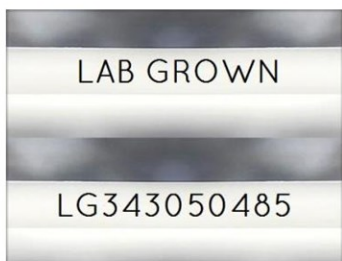
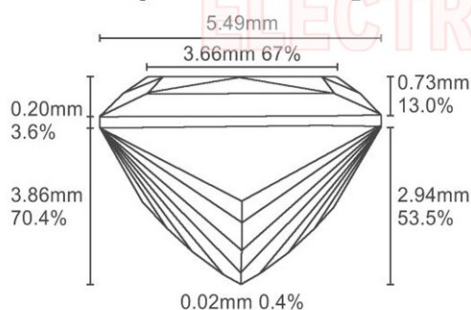

Illustration depicts approx. girdle appearance

Proportion Diagram



GCAL Certificate No. LG343050485

Scan QR code to view details of this lab grown diamond, grading scales, and to download a PDF of this certificate or go to <https://www.gcalusa.com/c/343050485>



4C's GRADING

Carat Weight	1.02
Color	D
Clarity	VS1
Cut	Excellent

Shape and Cutting Style	Princess
Measurements	5.57x5.49x3.86mm
Polish	Excellent
Physical Symmetry	Very Good
Optical Brilliance	Excellent
Optical Symmetry	Excellent
Table %	67%
Depth %	70.4%
Girdle	Medium - Sl.Thick
Culet	None
Fluorescence	None
Inscription	"LAB GROWN" & "LG343050485"
Growth Method	HPHT

This laboratory grown diamond was created by the HPHT (High Pressure High Temperature) method, and has the same chemical, physical and optical properties as a mined diamond.

Clarity Characteristics and Locations
Chip Crown Corner



The specifications noted in this certificate are accurate within recognized gemological tolerances. We stand behind our grading with a 4Cs Consumer Guarantee. Kindly see additional details, including the limitation of the guarantee, at www.GCALUSA.com.

GCAL BY SARINE

GCALUSA.com
T +1 212-869-8985
© GCAL USA LLC

Headquarters:
580 Fifth Ave, Flr. 27,
New York, NY 10036

Laboratories:
New York, USA
Surat, INDIA