

LAB GROWN DIAMOND

GCAL LG341900150

July 31, 2024



The fingerprint system for diamonds



ID No. NY02-695511

Gemprint is the unique optical fingerprint of your lab grown diamond. This patented technology is positive, forensic identification. Protect your investment and receive discounts up to 10% off your annual insurance premiums.

Register your diamond at Gemprint.com

Laser Inscription

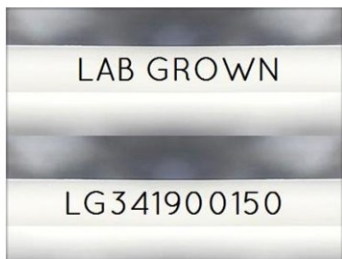
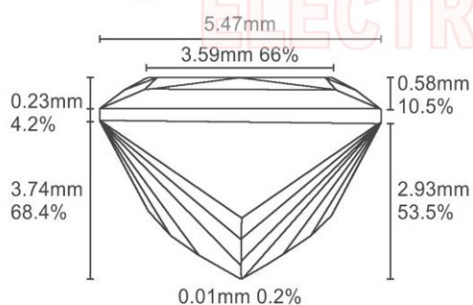

Illustration depicts approx. girdle appearance

Proportion Diagram



GCAL Certificate No. LG341900150

Scan QR code to view details of this lab grown diamond, grading scales, and to download a PDF of this certificate or go to <https://www.gcalusa.com/c/341900150>



4C's GRADING

Carat Weight	1.00
Color	F
Clarity	VS1
Cut	Ideal

Shape and Cutting Style	Princess
Measurements	5.49-5.47x3.74mm
Polish	Excellent
Physical Symmetry	Excellent
Optical Brilliance	Excellent
Optical Symmetry	Excellent
Table %	66%
Depth %	68.4%
Girdle	Sl.Thick - Thick
Culet	None
Fluorescence	None
Inscription	"LAB GROWN" & "LG341900150"
Growth Method	CVD

This laboratory grown diamond was created by the CVD (Chemical Vapor Deposition) method, and has the same chemical, physical and optical properties as a mined diamond.

Clarity Characteristics and Locations

Clouds Crown Step,Girdle-Half Moon



GCAL GEM CERTIFICATION & ASSURANCE LAB
ISO 17025 ACCREDITED FORENSIC LABORATORY

580 Fifth Ave, Flr 27, NYC, NY 10036
T 212-869-8985 GCALUSA.com



ISO/IEC 17025 2017
ANAB L2177-1 Accredited Testing Lab

© Gem Certification & Assurance Lab, Inc.