

# LAB GROWN DIAMOND

**GCAL LG341806180**

August 05, 2024



The fingerprint system for diamonds



**ID No. NY02-701306**

Gemprint is the unique optical fingerprint of your lab grown diamond. This patented technology is positive, forensic identification. Protect your investment and receive discounts up to 10% off your annual insurance premiums.

**Register your diamond at Gemprint.com**

## Laser Inscription

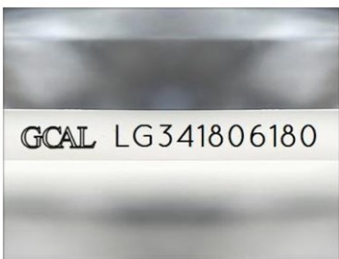
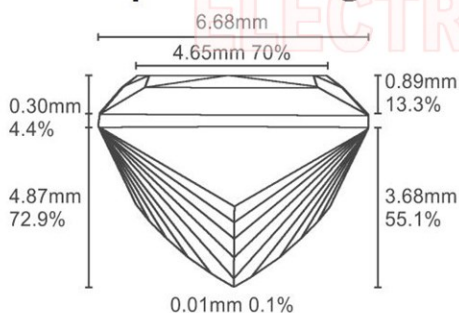

Illustration depicts approx. girdle appearance

## Proportion Diagram



**GCAL Certificate No. LG341806180**

Scan QR code to view details of this lab grown diamond, grading scales, and to download a PDF of this certificate or go to <https://www.gcalusa.com/c/341806180>



## 4C's GRADING

Carat Weight	2.03
Color	G
Clarity	VS1
Cut	Ideal

Shape and Cutting Style	<b>Princess</b>
Measurements	<b>6.91x6.68x4.87mm</b>
Polish	<b>Excellent</b>
Physical Symmetry	<b>Excellent</b>
Optical Brilliance	<b>Excellent</b>
Optical Symmetry	<b>Excellent</b>
Table %	<b>70%</b>
Depth %	<b>72.9%</b>
Girdle	<b>Sl.Thick - Thick</b>
Culet	<b>None</b>
Fluorescence	<b>None</b>
Inscription	<b>GCAL Logo &amp; "LG341806180"</b>
Growth Method	<b>CVD</b>

This laboratory grown diamond was created by the CVD (Chemical Vapor Deposition) method, and has the same chemical, physical and optical properties as a mined diamond.

### Clarity Characteristics and Locations

Crystals	Crown Shoulder, Table
Pinpoints	Crown



The specifications noted in this certificate are accurate within recognized gemological tolerances. We stand behind our grading with a 4Cs Consumer Guarantee. Kindly see additional details, including the limitation of the guarantee, at [www.GCALUSA.com](http://www.GCALUSA.com).

### GCAL BY SARINE

GCALUSA.com  
T +1 212-869-8985  
© GCAL USA LLC

Headquarters:  
580 Fifth Ave, Flr. 27,  
New York, NY 10036

Laboratories:  
New York, USA  
Surat, INDIA