

LAB GROWN DIAMOND

GCAL LG341806085

August 05, 2024



The fingerprint system for diamonds



ID No. NY02-701303

Gemprint is the unique optical fingerprint of your lab grown diamond. This patented technology is positive, forensic identification. Protect your investment and receive discounts up to 10% off your annual insurance premiums.

Register your diamond at Gemprint.com

Laser Inscription

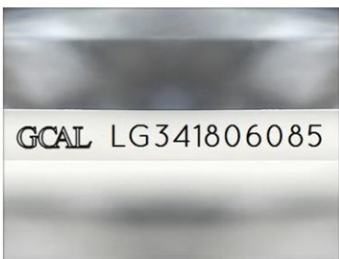
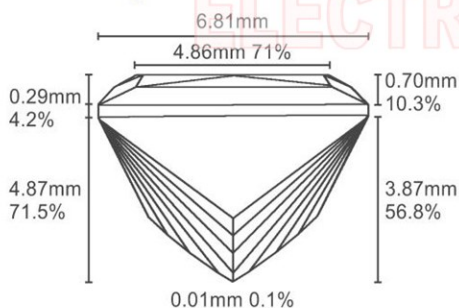

Illustration depicts approx. girdle appearance

Proportion Diagram



GCAL Certificate No. LG341806085

Scan QR code to view details of this lab grown diamond, grading scales, and to download a PDF of this certificate or go to <https://www.gcalusa.com/c/341806085>



4C's GRADING

Carat Weight	2.02
Color	F
Clarity	VS2
Cut	Ideal

Shape and Cutting Style	Princess
Measurements	6.86x6.81x4.87mm
Polish	Excellent
Physical Symmetry	Excellent
Optical Brilliance	Excellent
Optical Symmetry	Excellent
Table %	71%
Depth %	71.5%
Girdle	Sl.Thick - Thick
Culet	None
Fluorescence	None
Inscription	GCAL Logo & "LG341806085"
Growth Method	CVD

This laboratory grown diamond was created by the CVD (Chemical Vapor Deposition) method, and has the same chemical, physical and optical properties as a mined diamond.

Clarity Characteristics and Locations

Feather	Table
Pinpoints	Crown Shoulder, Table



The specifications noted in this certificate are accurate within recognized gemological tolerances. We stand behind our grading with a 4Cs Consumer Guarantee. Kindly see additional details, including the limitation of the guarantee, at www.GCALUSA.com.

GCAL BY SARINE

GCALUSA.com
T +1 212-869-8985
© GCAL USA LLC

Headquarters:
580 Fifth Ave, Flr. 27,
New York, NY 10036

Laboratories:
New York, USA
Surat, INDIA