

# LAB GROWN DIAMOND

**GCAL LG341726276**

August 05, 2024



The fingerprint system for diamonds



**ID No. NY02-701287**

Gemprint is the unique optical fingerprint of your lab grown diamond. This patented technology is positive, forensic identification. Protect your investment and receive discounts up to 10% off your annual insurance premiums.

**Register your diamond at Gemprint.com**

## Laser Inscription

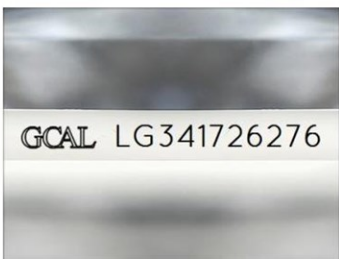
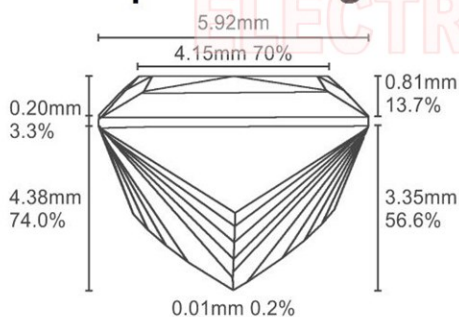

Illustration depicts approx. girdle appearance

## Proportion Diagram



**GCAL Certificate No. LG341726276**

Scan QR code to view details of this lab grown diamond, grading scales, and to download a PDF of this certificate or go to <https://www.gcalusa.com/c/341726276>



## 4C's GRADING

Carat Weight	1.42
Color	E
Clarity	VS1
Cut	Excellent

Shape and Cutting Style	Princess
Measurements	6.04x5.92x4.38mm
Polish	Excellent
Physical Symmetry	Very Good
Optical Brilliance	Excellent
Optical Symmetry	Very Good
Table %	70%
Depth %	74.0%
Girdle	Medium - Sl.Thick
Culet	None
Fluorescence	None
Inscription	GCAL Logo & "LG341726276"
Growth Method	HPHT

This laboratory grown diamond was created by the HPHT (High Pressure High Temperature) method, and has the same chemical, physical and optical properties as a mined diamond.

### Clarity Characteristics and Locations

Needles Crown Corner,Crown Step,Table



The specifications noted in this certificate are accurate within recognized gemological tolerances. We stand behind our grading with a 4Cs Consumer Guarantee. Kindly see additional details, including the limitation of the guarantee, at [www.GCALUSA.com](http://www.GCALUSA.com).

### GCAL BY SARINE

GCALUSA.com  
T +1 212-869-8985  
© GCAL USA LLC

Headquarters:  
580 Fifth Ave, Flr. 27,  
New York, NY 10036

Laboratories:  
New York, USA  
Surat, INDIA