

LAB GROWN DIAMOND

GCAL LG340960357

April 22, 2024



The fingerprint system for diamonds



ID No. NY02-671337

Gemprint is the unique optical fingerprint of your lab grown diamond. This patented technology is positive, forensic identification. Protect your investment and receive discounts up to 10% off your annual insurance premiums.

Register your diamond at Gemprint.com

Laser Inscription

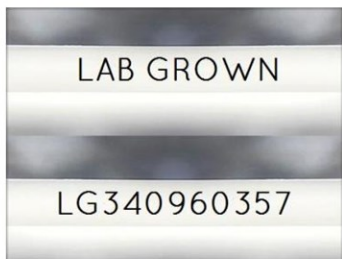
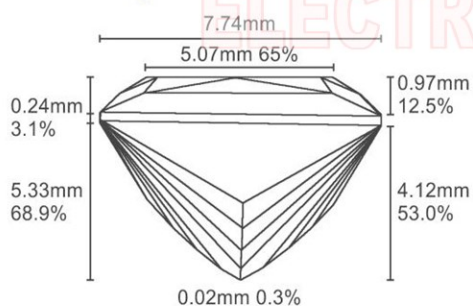

Illustration depicts approx. girdle appearance

Proportion Diagram



GCAL Certificate No. LG340960357

Scan QR code to view details of this lab grown diamond, grading scales, and to download a PDF of this certificate or go to <https://www.gcalusa.com/c/340960357>



4C's GRADING

Carat Weight	2.73
Color	E
Clarity	VS1
Cut	Excellent

Shape and Cutting Style	Princess
Measurements	7.76-7.74x5.33mm
Polish	Very Good
Physical Symmetry	Very Good
Optical Brilliance	Excellent
Optical Symmetry	Excellent
Table %	65%
Depth %	68.9%
Girdle	Medium
Culet	None
Fluorescence	None
Inscription	"LAB GROWN" & "LG340960357"
Growth Method	CVD

This laboratory grown diamond was created by the CVD (Chemical Vapor Deposition) method, and has the same chemical, physical and optical properties as a mined diamond.

Clarity Characteristics and Locations

Clouds	Table, Crown Shoulder
Chip	Crown Corner



GCAL GEM CERTIFICATION & ASSURANCE LAB
ISO 17025 ACCREDITED FORENSIC LABORATORY

580 Fifth Ave, Flr 27, NYC, NY 10036
T 212-869-8985 GCALUSA.com



ISO/IEC 17025 2017
ANAB L2177-1 Accredited Testing Lab

© Gem Certification & Assurance Lab, Inc.