

# LAB GROWN DIAMOND

**GCAL LG340580778**

March 7, 2024

## IDENTIFICATION DATA

**Gemprint** The fingerprint system for diamonds



**ID No. NY02-661590**  
Gemprint is the unique optical fingerprint of your lab grown diamond. This patented technology is positive, forensic identification. Protect your investment and receive discounts up to 10% off your annual insurance premiums. Register your diamond at [Gemprint.com](https://www.gemprint.com)

## Laser Inscription

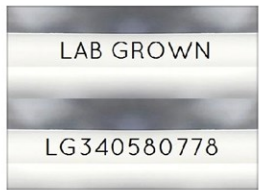
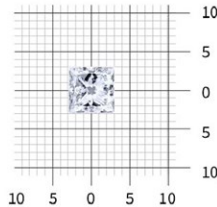

Illustration depicts approx. girdle appearance

## Actual Size



5.87 x 5.86 x 4.17 millimeters (mm)

## Proportion Diagram

Optical scanning technology measures each facet and angle to produce an accurate, to-scale diagram of this lab grown diamond.

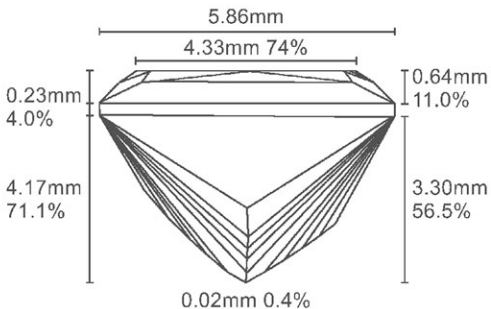

## PHOTOMICROGRAPHS



Actual photographs of the crown (top) and pavilion (bottom) of this lab grown diamond photographed at magnifications up to 10x. View hi-res photos at <https://www.gcalusa.com/c/340580778>

## Clarity Characteristics and Locations

ELECTRONIC COPY LIGHT PERFORMANCE PROFILE

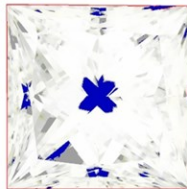

## Optical Brilliance **Excellent**

Optical Brilliance is the overall return of white light to the viewer. It is measured to the thousandth decimal place and is represented in this image. The white areas indicate light return / brilliance, and the dark blue areas indicate light loss.

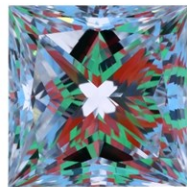

## Optical Symmetry **Good**

Optical Symmetry is visualized in this photograph of your lab grown diamond taken in a specific colored lighting environment. The evenness of the pattern illustrates the precision and uniformity of facet shapes and alignment.

**GCAL Certificate No. LG340580778**

Scan QR code to view photos of this lab grown diamond, grading scales, and to download a PDF of this certificate or go to <https://www.gcalusa.com/c/340580778>



## 4C's GRADING

Carat Weight	<b>1.24</b>
Color	<b>E</b>
Clarity	<b>IF</b>
Cut	<b>Very Good</b>

Shape and Cutting Style	<b>Princess</b>
Measurements	<b>5.87x5.86x4.17</b>
Polish	<b>Very Good</b>
Physical Symmetry	<b>Very Good</b>
Optical Brilliance	<b>Excellent</b>
Optical Symmetry	<b>Good</b>
Table %	<b>74%</b>
Depth %	<b>71.1%</b>
Girdle	<b>Thick</b>
Culet	<b>None</b>
Fluorescence	<b>None</b>
Inscription	<b>"LAB GROWN" &amp; "LG340580778"</b>
Growth Method	<b>HPHT</b>

This laboratory grown diamond was created by the HPHT (High Pressure High Temperature) method, and has the same chemical, physical and optical properties as a mined diamond.

## ONE LOCATION. ONE STANDARD. GRADED IN THE USA

Gem Certification & Assurance Lab has examined this lab grown diamond and certifies that the specifications noted in this document are accurate within recognized gemological tolerances. GCAL is an independent third-party and stands behind our grading with a 4Cs Consumer Guarantee. The guarantee, grading scales and all images unique to this lab grown diamond are available at [GCAL USA.com](https://www.gcalusa.com).



**Gem Certification & Assurance Lab, Inc.**  
ISO 17025 Accredited Forensic Laboratory  
580 Fifth Ave, Flr 27  
New York, NY 10036  
T 212-869-8985  
[GCALUSA.com](https://www.gcalusa.com)



ISO/IEC 17025 2017  
ANAB L2177-1 Accredited Testing Lab