

# LAB GROWN DIAMOND

**GCAL LG340451002**

February 28, 2024



The fingerprint system for diamonds



**ID No. NY02-658081**

Gemprint is the unique optical fingerprint of your lab grown diamond. This patented technology is positive, forensic identification. Protect your investment and receive discounts up to 10% off your annual insurance premiums.

**Register your diamond at Gemprint.com**

## Laser Inscription

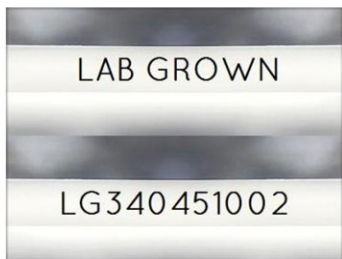
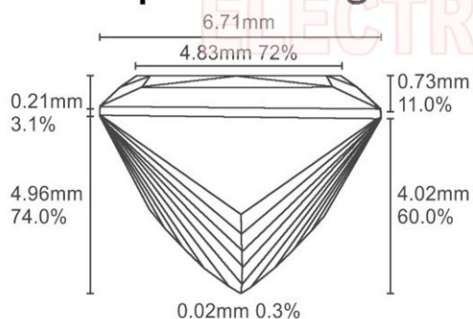

Illustration depicts approx. girdle appearance

## Proportion Diagram



## GCAL Certificate No. LG340451002

Scan QR code to view details of this lab grown diamond, grading scales, and to download a PDF of this certificate or go to <https://www.gcalusa.com/c/340451002>



## 4C's GRADING

Carat Weight	1.93
Color	E
Clarity	VS2
Cut	Excellent

Shape and Cutting Style	Princess
Measurements	6.91-6.71x4.96mm
Polish	Very Good
Physical Symmetry	Very Good
Optical Brilliance	Excellent
Optical Symmetry	Excellent
Table %	72%
Depth %	74.0%
Girdle	Medium - Sl.Thick
Culet	None
Fluorescence	None
Inscription	"LAB GROWN" & "LG340451002"
Growth Method	CVD

This laboratory grown diamond was created by the CVD (Chemical Vapor Deposition) method, and has the same chemical, physical and optical properties as a mined diamond.

Clarity Characteristics and Locations  
Crystals Table,Crown Step



**GCAL** GEM CERTIFICATION & ASSURANCE LAB  
ISO 17025 ACCREDITED FORENSIC LABORATORY

580 Fifth Ave, Flr 27, NYC, NY 10036  
T 212-869-8985 GCALUSA.com



ISO/IEC 17025 2017  
ANAB L2177-1 Accredited Testing Lab

© Gem Certification & Assurance Lab, Inc.