

LAB GROWN DIAMOND

GCAL 322880735

February 16, 2023



ID No. NY02-557810

Gemprint is the unique optical fingerprint of your lab grown diamond. This patented technology is positive, forensic identification. Protect your investment and receive discounts up to 10% off your annual insurance premiums. Register your diamond at [Gemprint.com](https://www.gemprint.com)

Laser Inscription

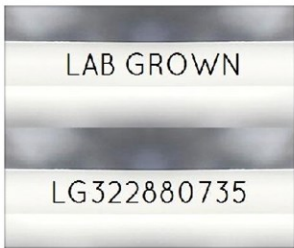
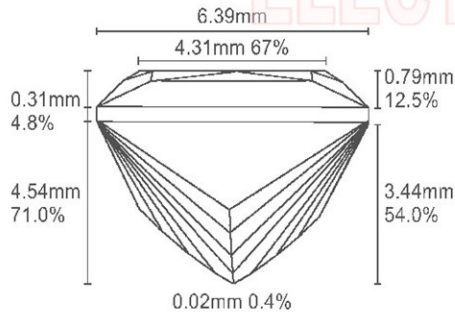

Illustration depicts approx. girdle appearance

Proportion Diagram



GCAL Certificate No. LG322880735

Scan QR code to view photos of this lab grown diamond, grading scales, and to download a PDF of this certificate or go to <https://www.gcalusa.com/c/322880735>



4C's GRADING

Carat Weight	1.67
Color	D
Clarity	VS1
Cut	Ideal

Shape and Cutting Style	Princess
Measurements	6.46x6.39x4.54
Polish	Excellent
Physical Symmetry	Excellent
Optical Brilliance	Excellent
Optical Symmetry	Excellent
Table %	67%
Depth %	71%
Girdle	Sl.Thick to Thick
Culet	None
Fluorescence	None
Inscription	"LAB GROWN" & "LG322880735"
Growth Method	HPHT



GICAL GEM CERTIFICATION & ASSURANCE LAB
ISO 17025 ACCREDITED FORENSIC LABORATORY

580 Fifth Ave, Flr 27, NYC, NY 10036
T 212-869-8985 GICALUSA.com



ISO/IEC 17025 2017
ANAB L2177-1 Accredited Testing Lab

© Gem Certification & Assurance Lab, Inc.

This laboratory grown diamond was created by the HPHT (High Pressure High Temperature) method, and has the same chemical, physical and optical properties as a mined diamond.

Clarity Characteristics and Locations

Crystals Table