

LAB GROWN DIAMOND

GCAL 322361240

September 13, 2022



ID No. NY02-520790

Gemprint is the unique optical fingerprint of your lab grown diamond. This patented technology is positive, forensic identification. Protect your investment and receive discounts up to 10% off your annual insurance premiums. Register your diamond at [Gemprint.com](https://www.gemprint.com)

Laser Inscription

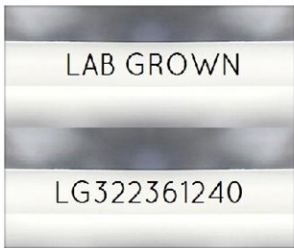
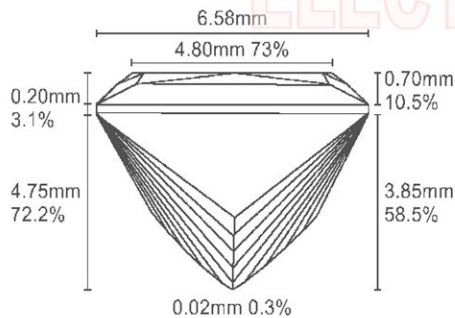

Illustration depicts approx. girdle appearance

Proportion Diagram



GCAL Certificate No. LG322361240

Scan QR code to view photos of this lab grown diamond, grading scales, and to download a PDF of this certificate or go to <https://www.gcalusa.com/c/322361240>



4C's GRADING

Carat Weight	1.74
Color	G
Clarity	VS1
Cut	Ideal

Shape and Cutting Style

Princess

Measurements

6.68x6.58x4.75

Polish

Excellent

Physical Symmetry

Excellent

Optical Brilliance

Excellent

Optical Symmetry

Excellent

Table %

73%

Depth %

72.2%

Girdle

Medium

Culet

None

Fluorescence

None

Inscription

"LAB GROWN" & "LG322361240"

Growth Method

CVD

This laboratory grown diamond was created by the CVD (Chemical Vapor Deposition) method, and has the same chemical, physical and optical properties as a mined diamond.

Clarity Characteristics and Locations

Cloud
Crystals, Feather

Crown Corner
Table



GCAL GEM CERTIFICATION & ASSURANCE LAB
ISO 17025 ACCREDITED FORENSIC LABORATORY

580 Fifth Ave, Flr 27, NYC, NY 10036
T 212-869-8985 [GCALUSA.com](https://www.gcalusa.com)



ISO/IEC 17025 2017
ANAB L2177-1 Accredited Testing Lab

© Gem Certification & Assurance Lab, Inc.