

# LAB GROWN DIAMOND

**GCAL 322361227**

September 13, 2022



**ID No. NY02-520770**

Gemprint is the unique optical fingerprint of your lab grown diamond. This patented technology is positive, forensic identification. Protect your investment and receive discounts up to 10% off your annual insurance premiums. **Register your diamond at Gemprint.com**

## Laser Inscription

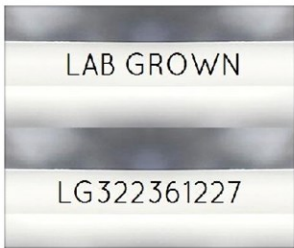
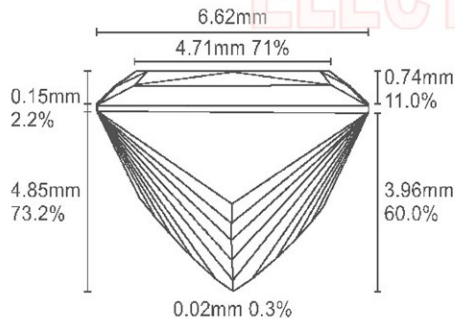

Illustration depicts approx. girdle appearance

## Proportion Diagram



**GCAL Certificate No. LG322361227**

Scan QR code to view photos of this lab grown diamond, grading scales, and to download a PDF of this certificate or go to <https://www.gcalusa.com/c/322361227>



## 4C's GRADING

Carat Weight	<b>1.78</b>
Color	<b>G</b>
Clarity	<b>VS1</b>
Cut	<b>Excellent</b>

Shape and Cutting Style	<b>Princess</b>
Measurements	<b>6.64x6.62x4.85</b>
Polish	<b>Excellent</b>
Physical Symmetry	<b>Excellent</b>
Optical Brilliance	<b>Excellent</b>
Optical Symmetry	<b>Very Good</b>
Table %	<b>71%</b>
Depth %	<b>73.2%</b>
Girdle	<b>Thin</b>
Culet	<b>None</b>
Fluorescence	<b>None</b>
Inscription	<b>"LAB GROWN" &amp; "LG322361227"</b>
Growth Method	<b>CVD</b>



**GCAL** GEM CERTIFICATION & ASSURANCE LAB  
ISO 17025 ACCREDITED FORENSIC LABORATORY

580 Fifth Ave, Flr 27, NYC, NY 10036  
T 212-869-8985 GCALUSA.com



ISO/IEC 17025 2017  
ANAB L2177-1 Accredited Testing Lab

© Gem Certification & Assurance Lab, Inc.

This laboratory grown diamond was created by the CVD (Chemical Vapor Deposition) method, and has the same chemical, physical and optical properties as a mined diamond.

### Clarity Characteristics and Locations

Crystals

Table, Crown Step