

Identification Data



August 16, 2021

LAB GROWN DIAMOND
Certificate No: 292960375

Gemprint®

Gemprint is the unique optical fingerprint for positive identification of your lab grown diamond. Register your lab grown diamond at www.Gemprint.com and receive insurance discounts up to 10%.



Laser Inscription:

The illustration depicts enlarged and approximate appearances of the inscriptions. Girdle laser inscribed "LAB GROWN" and "LG292960375"

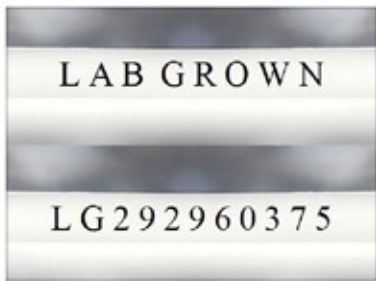

The 4Cs Grading Analysis

GCAL 292960375

LAB GROWN DIAMOND*

Carat Weight: 1.51

Cut: Very Good
Shape: Princess
Measurements: 6.22x6.16x4.47mm
Optical Brilliance: Excellent
Optical Symmetry: Good
Polish: Excellent
External Symmetry: Very Good
Girdle Thickness: Thick-Very Thick
Culet Size: None

Color: G
Fluorescence: None

Clarity: SI1
Identifying Characteristic(s): Feathers
Characteristic Location(s): Crown Step-Half Moon, Pavilion, Crown Step

*Comments: This laboratory grown diamond was created by the CVD (Chemical Vapor Deposition) method, and has the same chemical, physical, and optical properties as a mined diamond. This diamond is Type IIa, which means it is devoid of nitrogen impurities.

Photomicrographs:

Actual images of the crown (top) and pavilion (bottom) of this diamond photographed at magnifications up to 10x.



Light Performance Profile

Optical Brilliance Analysis:

Brilliance is the overall return of light to the viewer. The brilliance image is a representation of (a) white areas of light return, or brilliance, and (b) dark-blue areas of light loss.

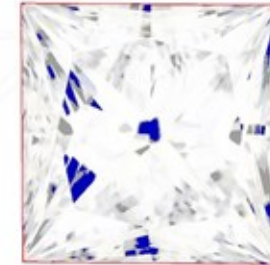

Optical Brilliance
Excellent

Optical Symmetry Analysis:

The colored areas of the symmetry image are indications of light handling ability, giving a visual representation of proportions and facet alignment.

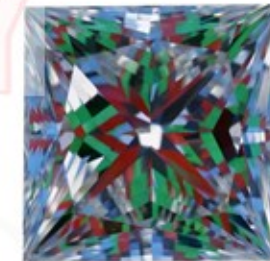

Optical Symmetry
Good

Proportion Diagram:

The proportion diagram illustrates the actual dimensions as recorded by optical scanning technology.

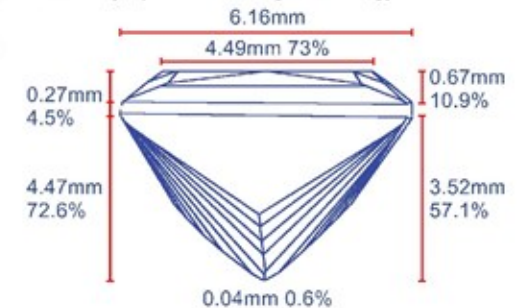

GCAL GEM CERTIFICATION & ASSURANCE LAB
ISO 17025 ACCREDITED FORENSIC LABORATORY

580 Fifth Ave LL-05
New York, NY 10036
T 212-869-8985
GCALUSA.com



ISO/IEC 17025 2017
ANAB L2177-1 Accredited Testing Lab