

## Identification Data

May 22, 2017

LAB GROWN DIAMOND  
Certificate Number 271240125



Gemprint is the unique optical fingerprint for positive identification of your lab grown diamond. Register your lab grown diamond at [www.Gemprint.com](http://www.Gemprint.com) and receive insurance discounts up to 10%.

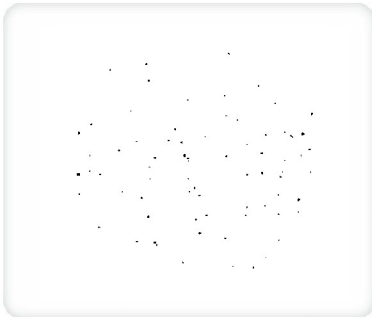

## Laser Inscription:

Actual image of the inscription photographed at magnification greater than 10x  
Girdle laser inscribed "LAB GROWN" and "LG271240125"

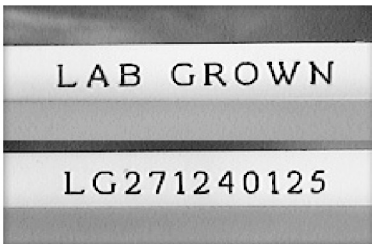

## The 4Cs Grading Analysis

GCAL 271240125

LAB GROWN DIAMOND\*

**Carat Weight:**

**0.84**

**Cut:**

**Very Good**

Shape:

Princess

Measurements:

5.13x5.04x3.63mm

Polish:

Good

External Symmetry:

Very Good

Girdle Thickness:

Medium-Sl.Thick

Culet Size:

None

**Color:**

**J**

Fluorescence:

None

**Clarity:**

**I2**

Identifying Characteristic(s): External Growth Characteristics

Characteristic Location(s): Crown-Girdle-Pavilion,Chevron

\*Comments: This man-made diamond was grown in a laboratory by the CVD method, and has the same chemical, physical, and optical properties as a natural earth mined diamond.

This lab grown diamond is classified as Type IIa, which is the most chemically pure type of diamond, and almost or entirely devoid of impurities. Only 1-2% of natural earth mined diamonds are Type IIa, whereas, colorless and near-colorless CVD lab grown diamonds are usually Type IIa.

## Photomicrographs:

Actual images of the crown (top) and pavilion (bottom) of this diamond photographed at magnifications up to 10x.



## Light Performance Profile

### Optical Brilliance Analysis:

Brilliance is the overall return of light to the viewer. The brilliance image is a representation of (a) white areas of light return, or brilliance, and (b) dark-blue areas of light loss.

Excellent

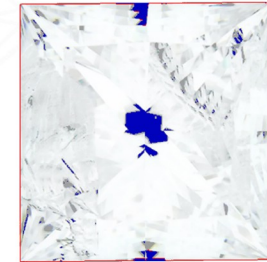

### Optical Symmetry Analysis:

The colored areas of the symmetry image are indications of light handling ability, giving a visual representation of proportions and facet alignment.

Good



### Proportion Diagram:

The proportion diagram illustrates the actual dimensions as recorded by optical scanning technology.

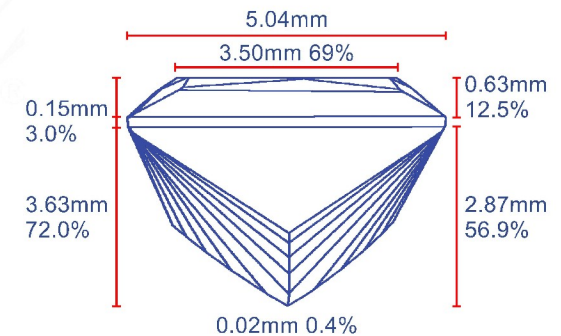

**GCAL**  
GEM CERTIFICATION & ASSURANCE LAB  
INTEGRITY GUARANTEED™



580 Fifth Avenue, New York, NY 10036, T 212.869.8985 F 212.869.2315  
[www.DiamondID.com](http://www.DiamondID.com), [www.GemFacts.com](http://www.GemFacts.com), [www.Gemprint.com](http://www.Gemprint.com)